



Specifications ODS Select - 2 Grey-Line :



Models Select-2:

ODS 72.5

ODS 75

ODS 82.5

ODS 95

ODS 120

Measurement data:

Measuring range	5 mm	10 mm	25 mm	50 mm	100 mm
Measuring range	70-75 mm	70-80 mm	70-95 mm	70-120 mm	70-170 mm
Center distance	72.5 mm	75 mm	82.5 mm	95 mm	120 mm
Resolution at short range *)	0.001 mm	0.001 mm	0.001 mm	0.001 mm	0.001mm
Resolution at long range *)	0.001 mm	0.001 mm	0.002 mm	0.002 mm	0.005 mm
Measurement Linearity *)	± 0.003 mm	± 0.004 mm	± 0.008 mm	± 0.013 mm	± 0.025 mm
Updating frequency *)	2 kHz	2 kHz	2 kHz	2 kHz	2 kHz
Temperature deviation	± 1.5 µ/C°	± 1.5 µ/C°	± 2.5 µ/C°	± 5 µ/C°	± 10 µ/C°
Light source / wave length	LASER / 655 nm	LASER / 655 nm	LASER / 655 nm	LASER / 655 nm	LASER / 655 nm
Size of spot	Ø 0.2 mm	Ø 0.3 mm	Ø 0.3 mm	Ø 0.4 mm	Ø 0.4 mm
Laser protection class	IEC 2	IEC 2	IEC 2	IEC 2	IEC 2

Output data

Electrical data

Environment data

Physical data

Analog output **):	4-20 mA or 1-9 V	Supply voltage	22 - 36 VDC	Operating temperature	0 - +45 C°	Dimensions	95*120*30 mm
Digital output ***):	RS232 or RS422	Power consumption	max 4.5 W	Storage temperature	-20 - +70 C°	Weight excl. Cable	370 g
Baud rate: 115200 for:	2 kHz output frequency			Humidity non condensing	Max 90 % RH	Cable length	2.5 m
Baud rate: 38400 for:	1 kHz output frequency			Degree of protection	IEC IP65	Housing	Aluminum

*) Static measurement on white paper at measuring/sampling frequency, without any averaging of the serial output signal: 2 · » 2 times the standard deviation.

**) Analog output Resolution: 14 Bit DAC's are used for the conversion of the 18 bit digital distance result, an integer value with a nominal resolution of 0.001 mm.

***) Serial/Digital and Analog output are updated at the measuring frequency of 2 kHz except if the Simple Average Filter is activated.

[More information on back page >](#)

Measuring frequency 2 kHz

Output rates are user specified, as the sensor can be programmed to make an average of up to 200 measurements (disregarding all zero/missing values) and output it as a single point. In this way the output rate can be lowered from 2000 Hz in steps down to 10 Hz. This is done with the Simple Average Filter.

The baud rate can also be changed. An output frequency of 2 kHz requires a baud rate of 115200. 38400 baud will reduce serial output rate to 1 kHz.

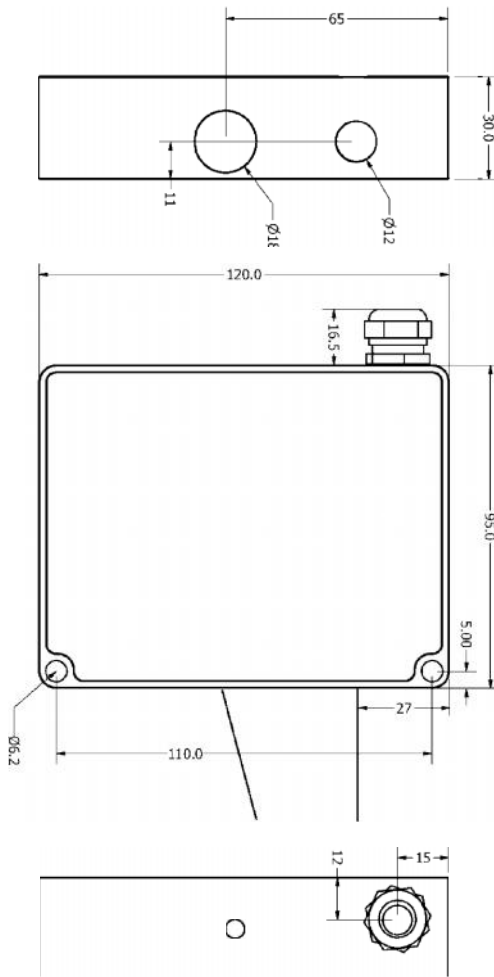

Filter & User Settings available

All ODS Gray-Line sensors have a programming / Select functionality.

There are 3 kinds of averaging filters, Median Filter, Simple Average and Running Average Filter. These filter settings can be set individually and operate simultaneously (and additive), as can most other user settings.

In Group Mode a running average is calculated over a user specified number of measuring points (group). The user also programs the sensor to disregard a number of bad (zero) / missing measuring points before calculating the average value. It is recommended to suppress the maximum number of "0" values. The running average value is calculated at full measuring frequency and is also used for converting the analog signal, either 4-20 mA or 1-9 V.

The Simple Average Filter compresses a number of measuring points, from 1 to 200, into one single output value by making an average disregarding any "0"/missing values present.

Several Median filters, actually from 3 to 31 is available, as well as Sample Hold Mode, where the last valid measurement value is kept as the output value in case of missing "0" measuring points.

Level Mode inverts the measuring values, in this setting the closer distances will be output as high values whereas distances far away will be output as low values.

2 ODS Gray-Line sensors can be interconnected to automatically form a thickness/width measuring system. See next paragraph. This default setting can be change to a Difference setting/mode, where any difference in the measured distance of the 2 sensors is reflected in the output of the Master sensor as being either in the high or low domain of the measuring range.

ODS Thickness Measurement

ODS Gray-Line sensors are calibrated for measuring thickness when paired.

An ODS Gray-Line sensor will automatically turn itself into being either the Master or the Slave half part of a thickness measuring system when connected to an identical ODS sensor model.

The Master sensor reads the digital distance data as send from the Slave sensor over their RS232 or RS422 serial interfaces, and after taking its own distance information into account, it will output the change in thickness in its calculated digital form as well as a converted analog signal. The sensors must always be synchronized, and will measure on transparent targets alternately from one side if they are wired to measure at 1 kHz (half) frequency.

A couple of ODS sensors will thus measure thickness or width without any control box or special calibration from the factory. ODS sensors can also be programmed to operate in Difference Mode instead of measuring thickness. This unique characteristic of the ODS sensors is also available in models of the Black-Line and Red-line families.

