

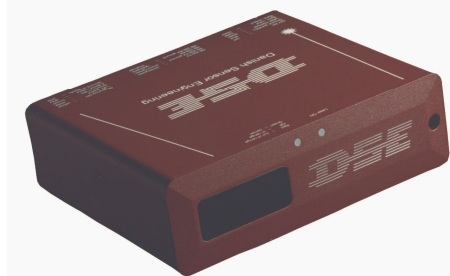

Specifications: ODS Red-Line 5 kHz series



Select-5 Models :	ODS 505	ODS 500-1100	ODS 925	ODS 1150	ODS 1950	ODS 1400	ODS 3000
High Target Temperature:	+	+	+	+	+	+	+
Measurement data:							
Measuring range	100 mm	200 mm	650 mm	900 mm	900 mm	1400 mm	2000 mm
Measuring range	450–550 mm	Center ± 100 mm	600–1250 mm	700–1600 mm	1500-2400 mm	700-2100 mm	2000-4000 mm
Center distance	500 mm	500, 700 and 1100 mm	925 mm	1150 mm	1950 mm	1400 mm	3000 mm
Resolution *)	< 0.01 mm	0.05 mm	< 0.1 mm	0.1 mm	0.2 mm	0.3 mm	0.5 mm
Reproducibility *)	± Resolution	± Resolution	± Resolution	± Resolution	± Resolution	± Resolution	± Resolution
Linearity *)	± 0.05 mm	± 0.10 mm	± 0.3 mm	< ± 0.4 mm	± 0.5 mm	± 0.7 mm	± 1.0 mm
Updating frequency	5 kHz	5 kHz	5 kHz	5 kHz	5 kHz	5 kHz	5 kHz
Temperature deviation	± 0.03% FS/C°	± 0.03% FS/C°	± 0.03% FS/C°	± 0.03% FS/C°	± 0.03% FS/C°	± 0.03% FS/C°	± 0.03% FS/C°
Light source (nm)	LASER (655/670)	LASER (655/670)	LASER (655/670)	LASER (655/670)	LASER (655/670)	LASER (655/670)	LASER (655/670)
Size of spot	App. Ø 1 mm	Ø 2-3 mm	Ø 4 mm	Ø 4 mm	Ø 5 mm	Ø 5 mm	Ø 5 mm
Laser protection class	IEC 2	IEC 2/3R	IEC 3R	IEC 3R	IEC 3R	IEC 3R	IEC 3R
Output data:		Electrical data:		Environment data:		Physical data:	
Voltage output **):	1-9 V DC	Supply voltage	24 VDC ± 10%	Operating temperature	0 - +45 C°	Dimensions	230*70*200 mm
Current output **):	4-20 mA	Power consumption	Max 4.5 W	Storage temperature	-20 - +70 C°	Weight excl. Cable	4.0 Kg
Digital output:	RS232 or RS422			Humidity non condensing	Max 90 % RH	Cable length	2.5 m
Baud rate: 38400 (default)	1 kHz output frequency			Degree of protection	IEC IP64	Housing	Steel/ Aluminum/Glass
Baud rate: 115200	2½ kHz output frequency						
Baud rate: 230400	5 kHz output frequency	(Requires RS422)					

*) Static measurement on white paper at full sampling/measuring frequency without any averaging of the output signals. Sampling and output frequency being identical.

**) HT models will as standard specification have a higher laser class. ODS 505 HT and ODS 500 HT laser class IEC 3R the other models in HT form laser class IEC 3B.

***) Analog outputs are always updated at the measuring frequency of 5 kHz whether the serial interface is set to operate at 38400,115200 or 230400baud (1 or 2½ or 5 kHz).

Measuring frequency 5 kHz

The serial interface of the ODS Select-5 Red-Line models can operate at either 1.000, 2.500 or 5.000 measurements/sec

All ODS Red-Line sensors/meters have a version of the Select functionality. The main feature is Group Mode.

In Group Mode a running average is calculated over a user specified number of measuring points. The user also programs the meter to disregard a number of, usually all (if there are any zero measurement results), before calculating the average value. The average values are calculated at full measuring frequency and are used for converting the analog signals.

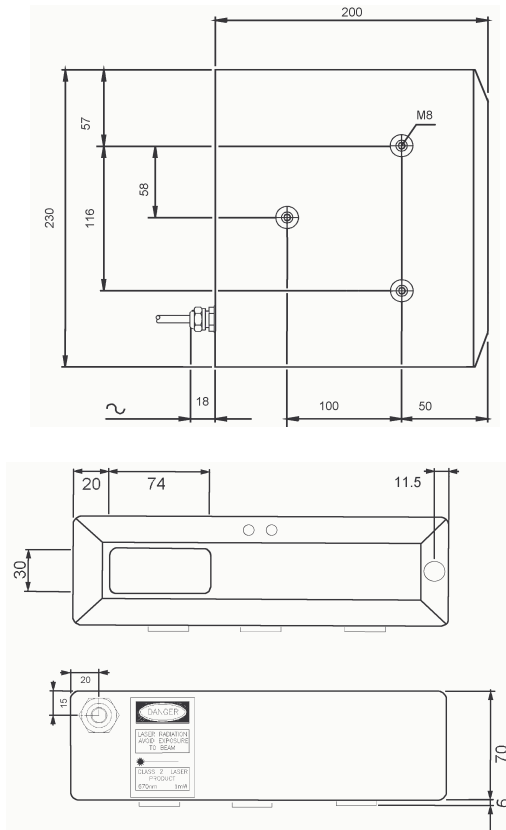

ODS Thickness Measurement

ODS Red-Line sensors are calibrated for measuring thickness when paired.

All ODS Red-Line sensors will automatically turn itself into being either the Master or the Slave half part of a thickness measuring system when connected to an identical ODS sensor model.

The Master sensor reads the digital distance data send from the Slave sensor over the RS232/422 serial interface, and after taking its own distance information into account, it will output the change in thickness in its calculated digital form as well as a converted analog signal. The sensors must be synchronized and will measure on transparent targets alternately from one side if they are wired to run at half the measuring frequency.

A couple of ODS sensors will thus measure thickness or width without any control box or special calibration from the factory. This unique characteristic of the ODS meters are available in all the Select (5 kHz) versions and also in the HT high target temperature models in the Red-Line range of models.

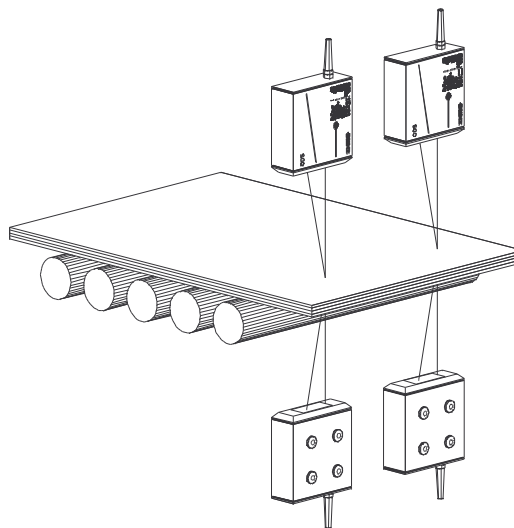

ODS High Temperature models

The HT models are designed for target surfaces temperatures up to 1200 °C.

Because of the non-contact measurement method, the ODS Select HT sensors are specially designed for measurement on objects that are more than 450 °C hot like hot rolled steel or molten metals and glass. Laser class 3R sensors achieve target temperature up to 1200 °C, for surfaces with mirror type properties a special sensor with laser class 3B can be needed.

All the models in the ODS Red-Line family can be delivered in HT specification. The HT feature can be specified for the 1 kHz and 2 kHz Red-Line models in laser class 2 form.

It is important to stress, that the HT specification only concerns the target temperature. Maximum environment temperature is the usual 45 °C.

The HT specification can also be necessary when there is a high risk of harmful false light as is the case with bright sunlight, both direct and reflected.

